

## Descriptions:



### **100MM 4 Inch Diamond Single Row Grinding Cup Wheel For Construction Material Grinding Disc**

**4 Inch Single Row Grinding Cup Wheel.** The single-row bowl mill adopts a unique processing production process to ensure the perfect combination of the cutter head and the base body, the shape is precise, the grinding effect is good, the grinding efficiency is high, and the service life is long.

**4 Inch Single Row Grinding Cup Wheel** for different grinding objects, different binders and different choices need to be selected. This single row cup wheel is designed for fast removal rates and long lifespan.



## Specifications:

The following are normal specifications 4 Inch Single Row Grinding Cup Wheel:

Name:	4 Inch Single Row Grinding Cup Wheel
Bore:	M14, 22.23, 5/8"-11
Blank Material:	45Mn Steel
Diameter:	4 Inch (D100mm)
Segment Size:	30*5.0*8mm
Surface Finishing:	Color Painting
Grits Available:	Coarse, medium, fine
Material:	Diamond And Metal Powder
Segments Type:	4 Inch Single Row Segment
Bond Available:	Soft Bond, Medium Bond, Hard Bond
Machine:	Angle Grinder or General Grinding Machine
Process:	Cold Pressed Sintered,High-Frequency Welded

Specially designed tools are available for any standard application. We can Tailor your tools to your specific needs.

### **Product Details:**

#### **4 Inch Single Row Grinding Cup Wheel:**

Single Row Segment  
30\*5.0\*8.0mm







# SINGLE ROW GRINDING CUP WHEEL



Fast Grinding  
5MM workable thickness  
3MM Strong Core Steel

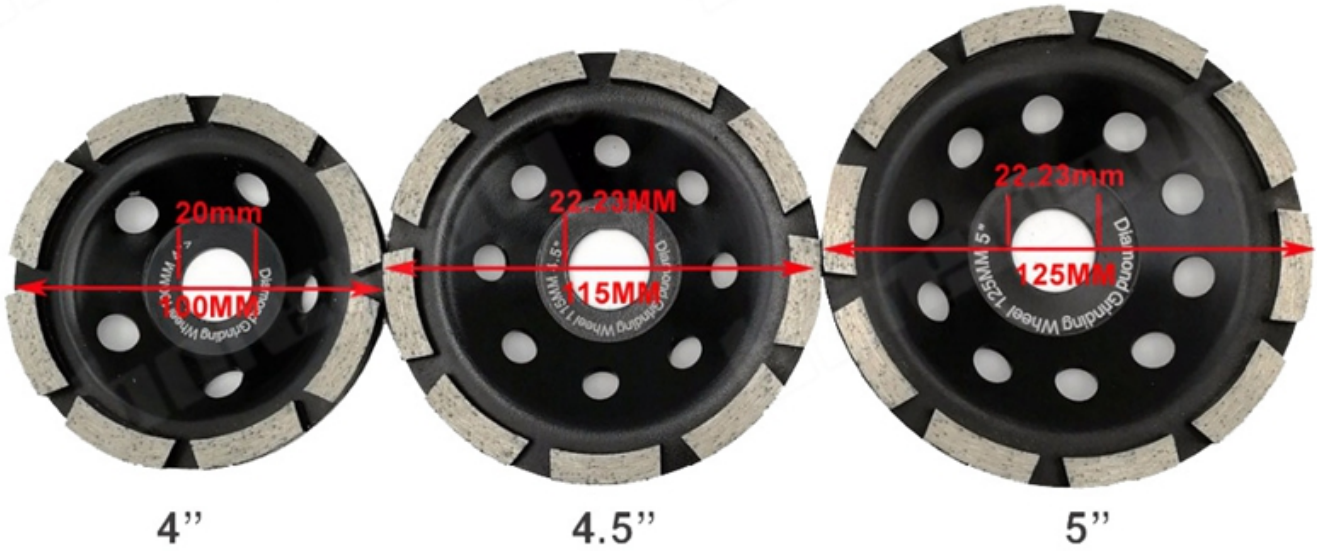

4"

4.5"

5"



E6 diamond powder ,one of the best quality diamond powder in the world.

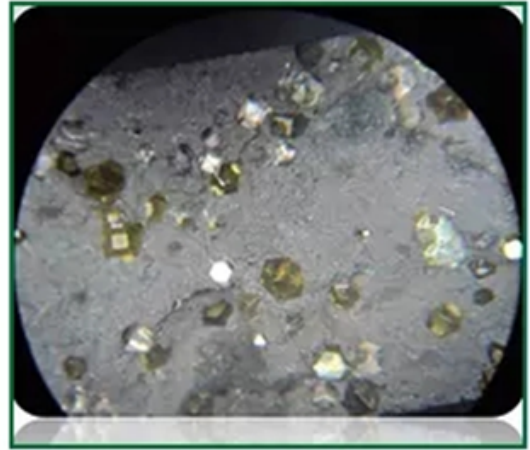

Diamond powder under the microscope

[If you are interested in our products, you can click on me.](#)

#### Applications:

**4 Inch Single Row Grinding Cup Wheel** for concrete, Masonry, granite marble and some other construction material.







**Choice Grit:**



4 Inch Single Row Grinding Cup Wheel metal bond diamonds high grinding efficiency and low grinding force generates less heat in the grinding process.

1) Coarse grit: 16#,24#,25#,30# etc.

Could be used for un-even concrete floors, rough grinding preparation on floor or old floor renovation.

2)Medium grits: 36#, 50/60# , 60/80# etc.

Could be used for all kinds of concrete and terrazzo floors, grinding preparation on floor or old floor renovation.

3) Fine grits: 80/100# , 100/120#, 120/150#, 200# etc.

Could be used for all kinds of concrete and terrazzo floors, find grinding preparation on floor or old floor renovation before polishing.

### **Advantages:**

1. 4 Inch Single Row Grinding Cup Wheel venting holes for fast, dry or wet grinding with long life.
2. Grinding segments with heat treated steel bodies which provide increases durability and wheel life.
3. The high diamond concentration provides for a faster cut rate while the high quality of the diamonds provides longer blade life.

### **Features:**

1. Venting holes for fast, dry or wet grinding with long life.
2. Turbo Row Cup Wheel is ideal for beveling, smoothing and shaping.
3. Grinding segments with heat treated steel bodies which provide increases durability and grinding life.
4. 4 Inch Single Row Grinding Cup Wheel suitable for use on grinding on marble, tile, concrete, and rock.

5. The high diamond concentration provides for a faster cut rate while the high quality of the diamonds provides longer blade life.

**Related Products:**

**4 Inch Single Row Grinding Cup Wheel:**

Outer Diameter		Segment Size(mm) (L*W*H)	Core	Diamond Grit
Inch	mm			
4	100	30*5.0*8.0	22.23, M14, 5/8"-11 etc.	30#, 50#, 100#
4.5	115	30*5.0*8.0		30#, 50#, 100#
5	125	40*5.0*8.0		30#, 50#, 100#
7	180	28*5.0*8.0		30#, 50#, 100#



Boreway Machinery Co., Ltd  
www.diamondtools.biz  
www.boreway.com

[4.5 Inch Diamond Grinding Cup Wheel](#)



Boreway Machinery Co., Ltd  
www.diamondtools.biz  
www.boreway.com

[5 Inch Diamond Grinding Cup Wheel](#)

**About us:**



### **Our service:**

1. Low order quantity: It can meet the test order you need.
2. Fast delivery: We get great discounts from freight forwarders.
3. OEM Acceptable: We can produce according to your samples or drawings.
4. Good quality: We have a strict quality control system. Has a good reputation in the market.
5. Good service: We regard our customers as God with a high degree of professionalism and enthusiasm.

### **Please note:**

1. Please provide items before purchase.
2. Please provide the model number before purchase.
3. Other specifications can be customized according to requirements.

### **Contact us:**

# Fujian Nanan *boreway*<sup>®</sup> Machinery Co.,Ltd.

 No.605 Huahui Center, Shuitou Town 362342 Quanzhou, Fujian, China

 **TEL:** (+86)595-86990206 /  **Fax:** (+86)595-86990220

 **Mobile/WhatsApp/Wechat:** (+ 86) 13559599186

 **E-mail:** [boreway05@boreway.net](mailto:boreway05@boreway.net)

 **Kelly Huang**